

# Distributed Generation

---

## Interconnection challenges & opportunities

Alourdes Sully, M. Eng. Mgmt., P.Eng.

Team Lead – Project Engineering  
Distributed Generation Connections  
Hydro One Networks Inc.

February 18, 2010

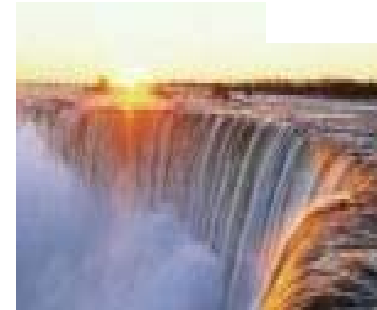

# Agenda

- Driving Forces
- Background
- Challenges
- Opportunities
- Conclusion



# Driving Forces: Diversity of Supply Capacity

## □ Ontario Installed & Projected Supply Capacity 2009-2014

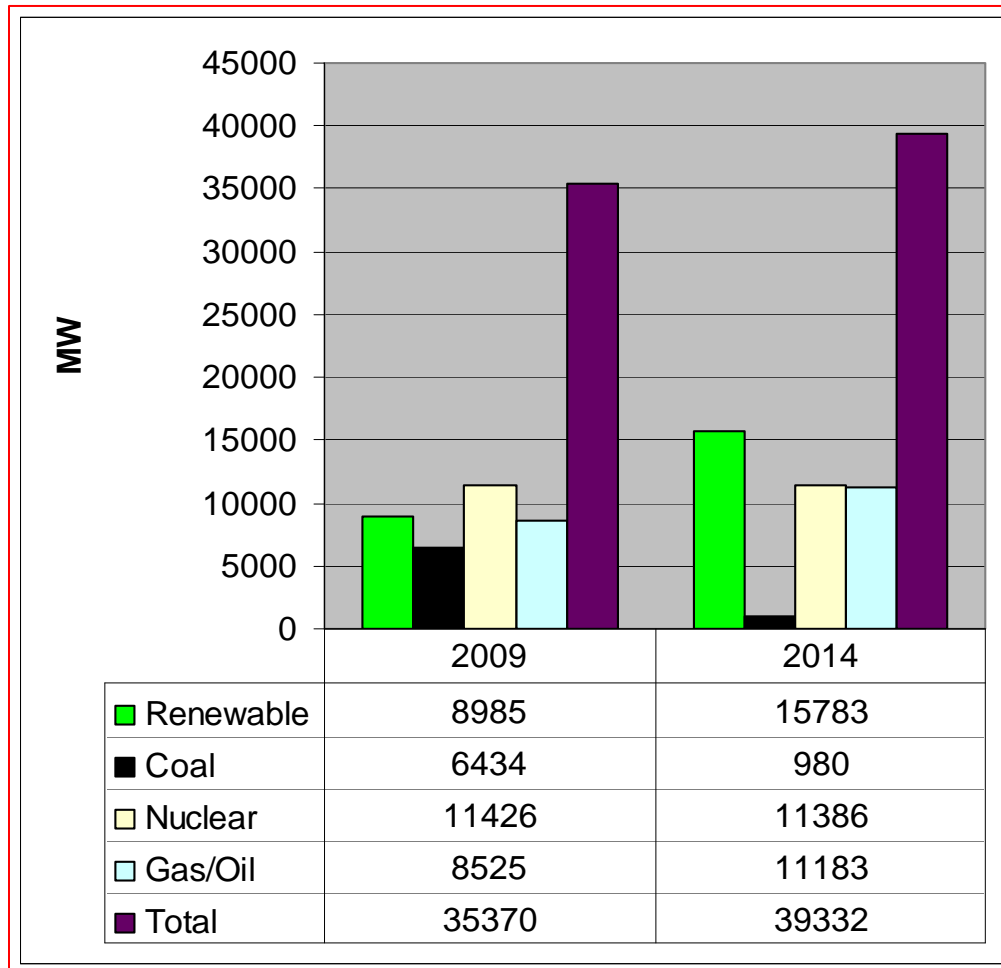

- ❖ Security of supply
  - Diversity of energy sources
- ❖ Environmental concerns
  - Use of renewable energy
  - Reduce greenhouse gas emissions
  - Promote a culture of conservation



Source: Ontario Power Authority

# Focus on Green Energy & Green Jobs

Renewable Supply Capacity  
2009-2014

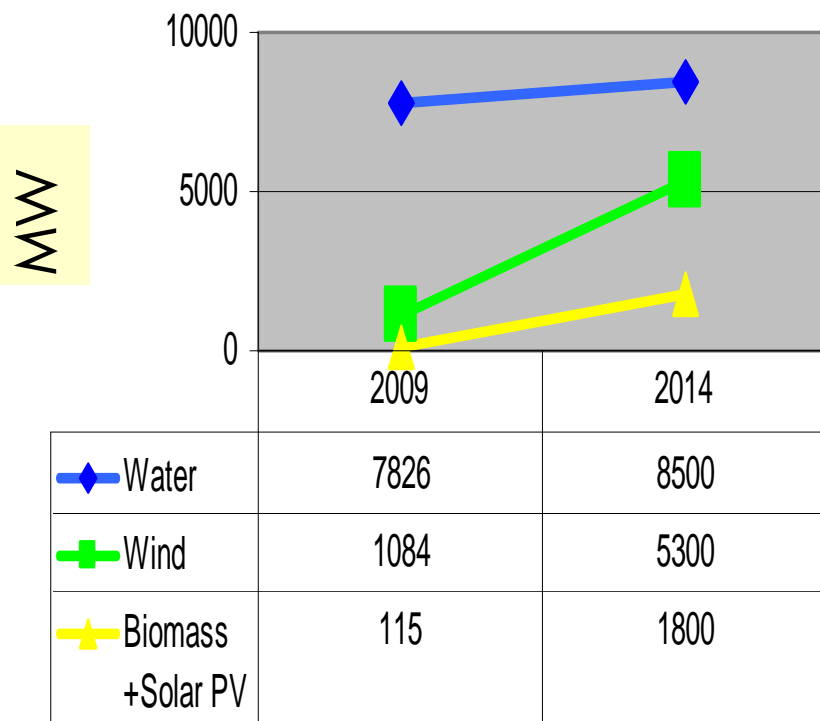

## Government Initiatives

- ❖ 2006, Standard Offer Program for Renewable Energy (RESOP)
  - Interconnection to the grid of projects from 1 kW to 10 MW
- ❖ 2009, Green Energy Act (GEA)
  - ❖ Feed-in Tariff (FIT) Program
    - **MicroFIT below 10 kW**
    - **FIT 10 kW and Higher**



# Background

## ❑ Centralized Electrical Power System

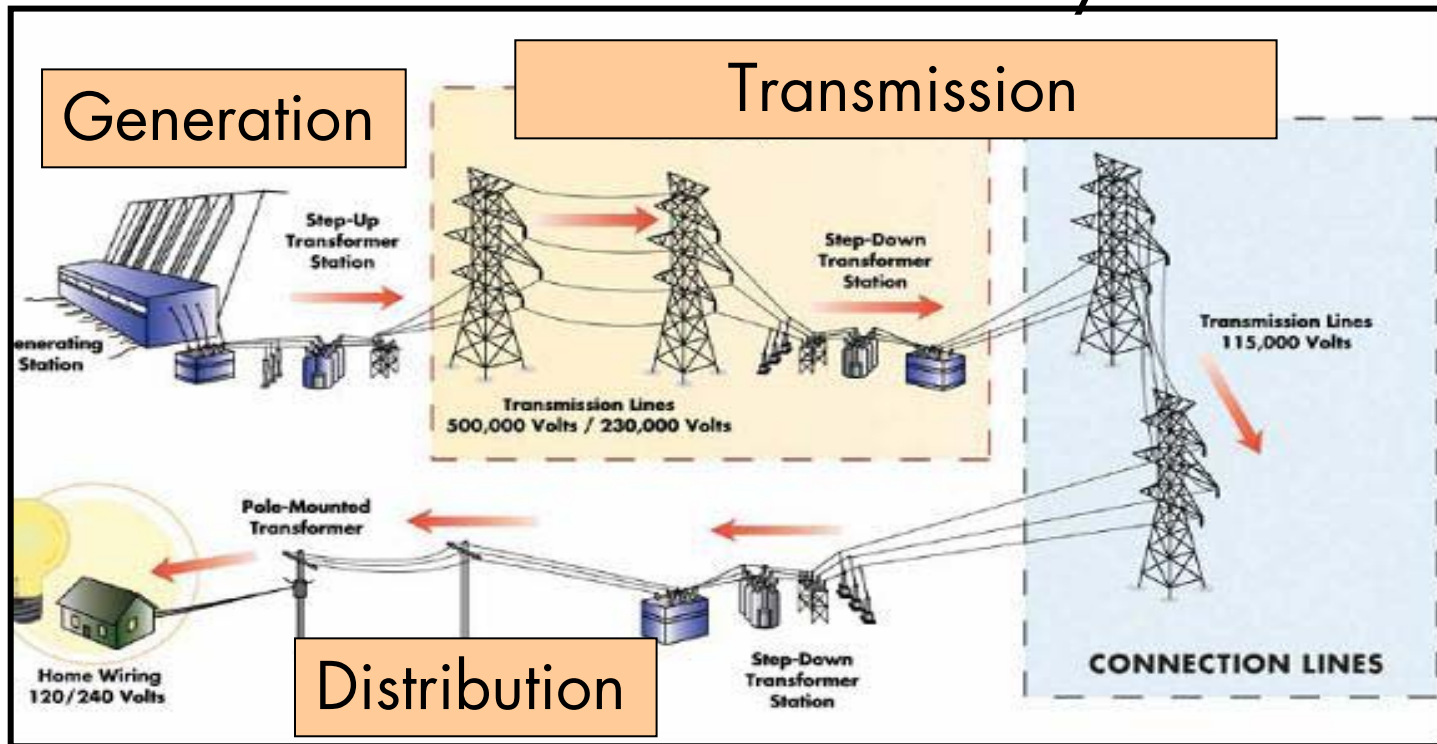

- ❖ **Transmission System:** 50kV and Higher (115kV, 230kV, 500kV)
- ❖ **Distribution System:** 50kV and Below (44kV, 27.6kV, 13.8kV, ...)
- ❖ **Generation:** Nuclear, Hydro, Thermal

✓ Power flow is unidirectional from higher to lower voltage levels. Distribution System is designed to serve load customers.

# □ Decentralized Electrical Power System

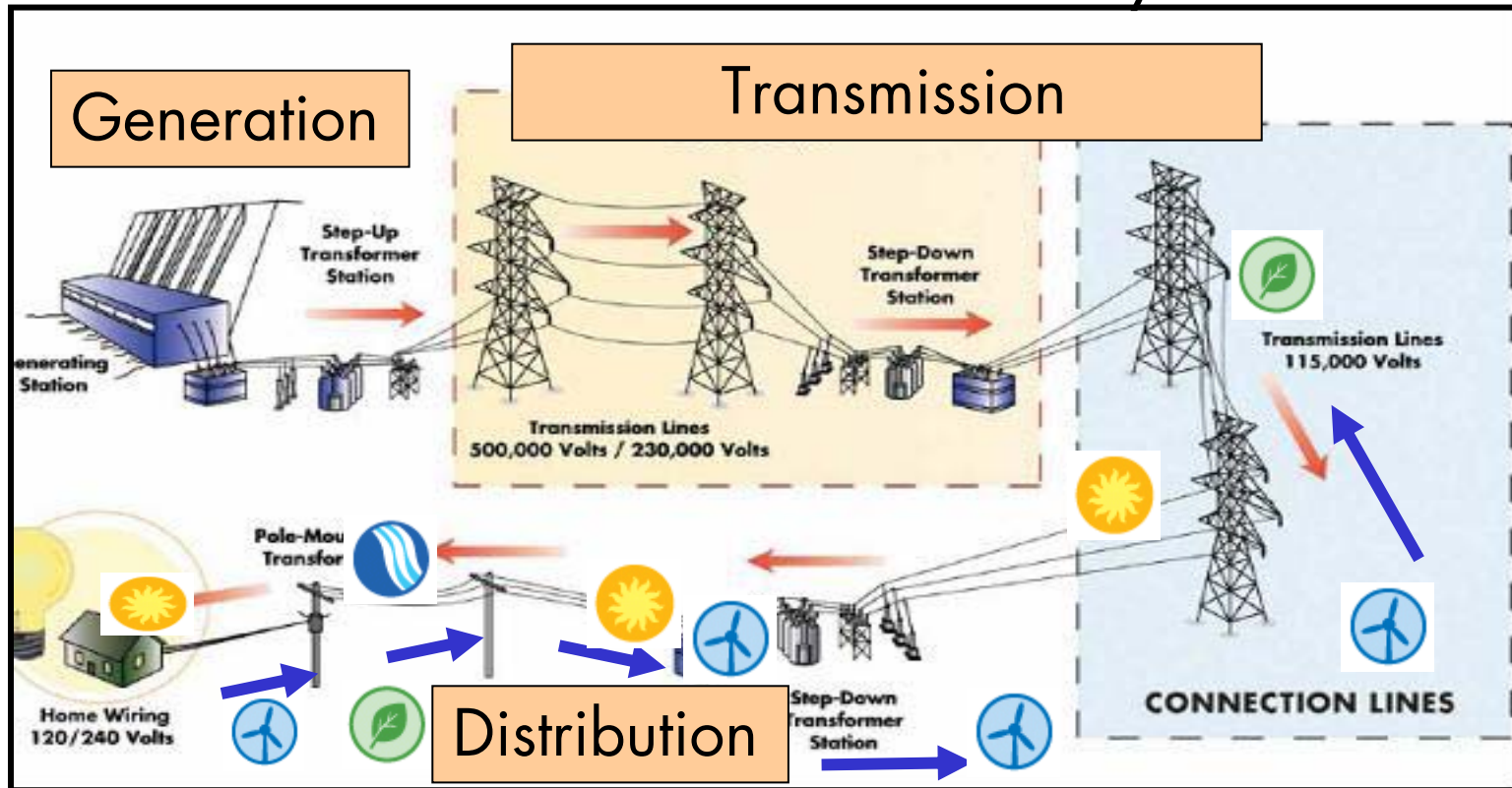

## ❖ Distributed Generation (DG)

 Hydro    Solar    Wind    Bio-Energy

✓ Reverse Power Flow to the Grid

# Distributed Generation Connections @ 50kV or Below

## □ Key Objectives

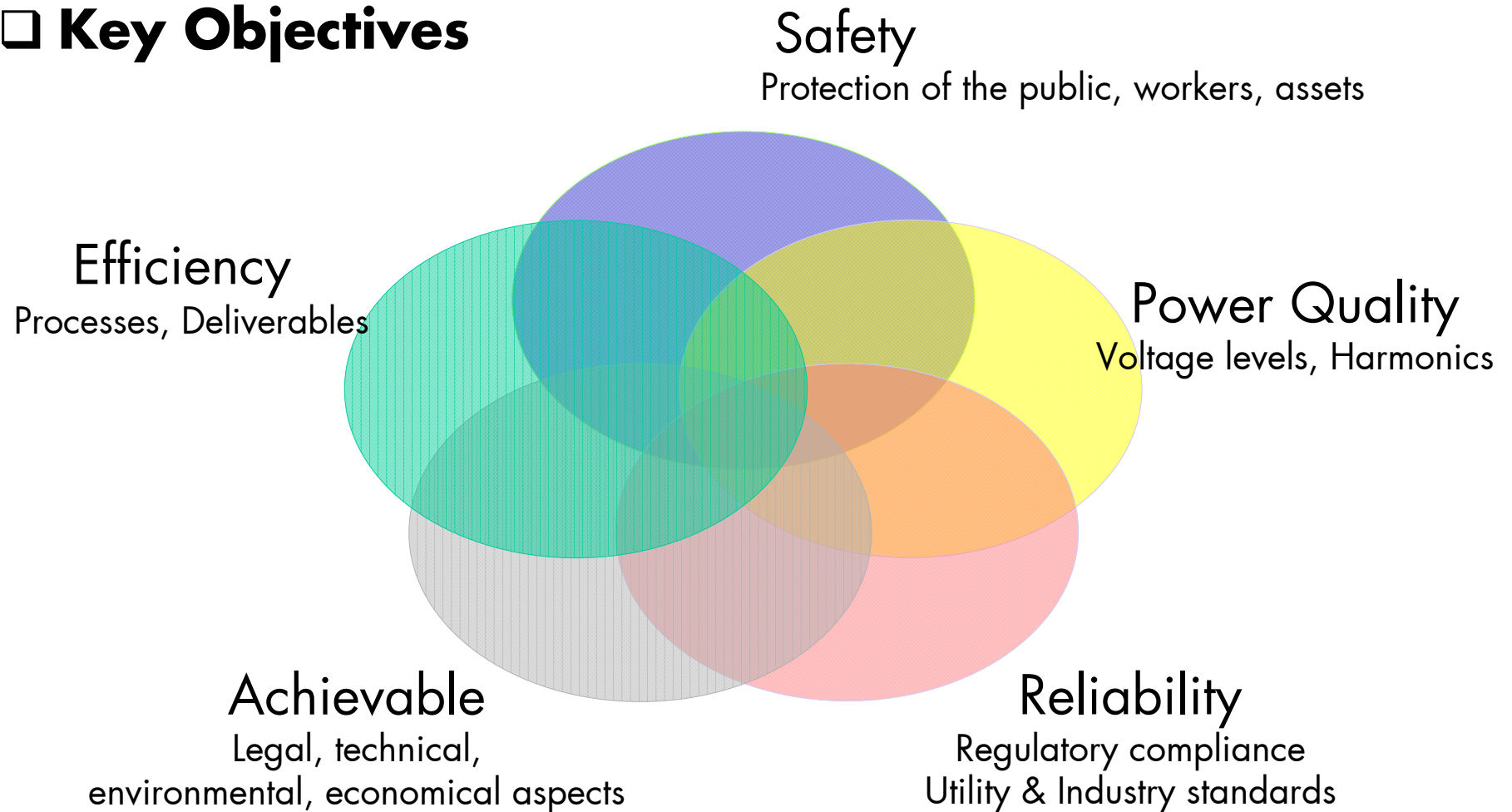

# Distributed Generation (DG): Connection Overview

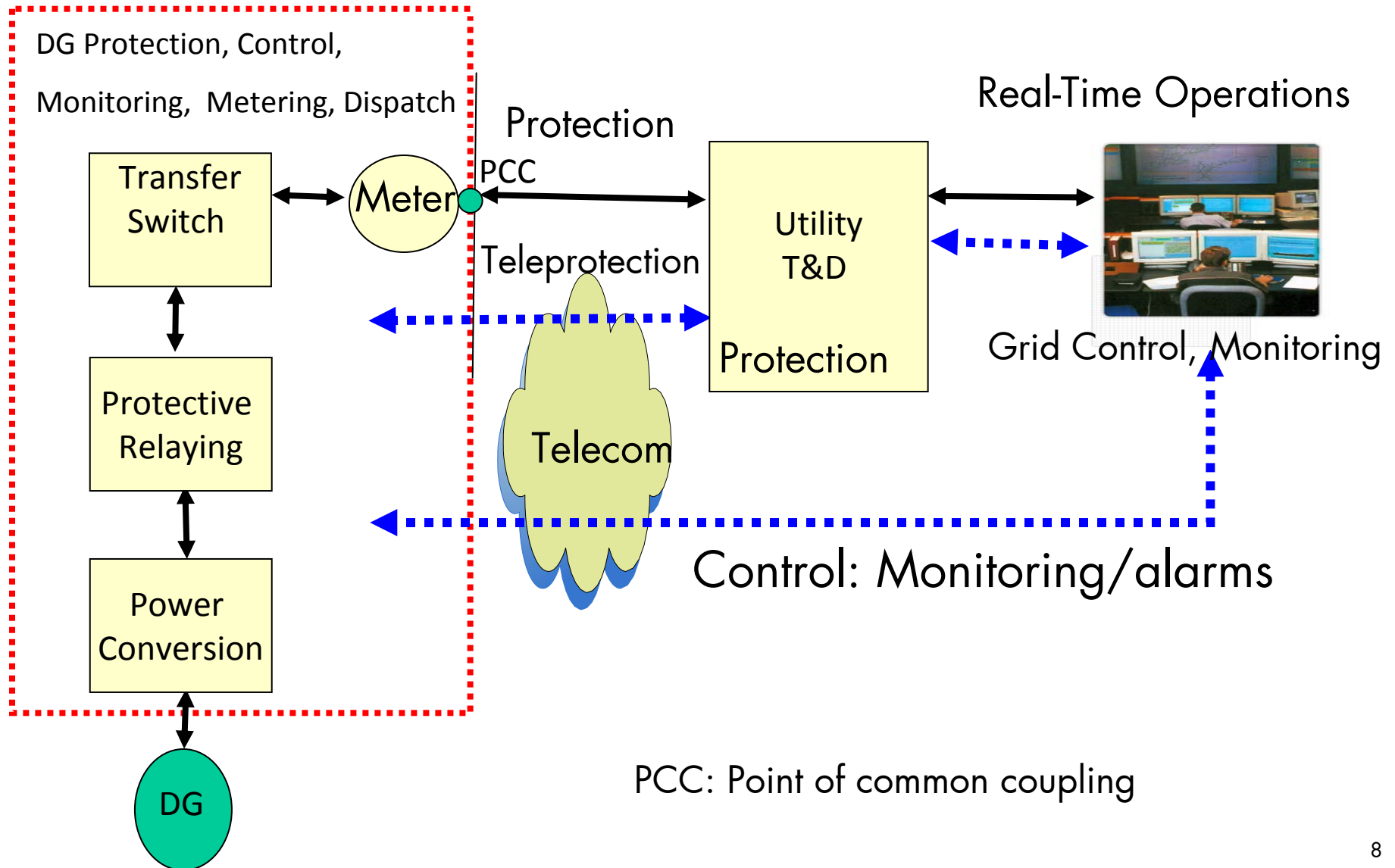

# Protection & Telecom Roles

## □ Protection

Means isolation of a faulty line & deals with Protective Relays

- ✓ Dependable: Operate when required
- ✓ Secure : Not operate unnecessarily
- ✓ Selective: Only the minimum required number of devices must operate
- ✓ Fast: To minimize hazards to personnel and damage to equipment

## □ Why Telecom?

- ✓ Provides Transport capability to Teleprotection and Supervisory Control and Data Acquisition (SCADA)
- Telecom Medium includes: Leased circuits (Analog or digital), Optical Fiber, Wireless

❖ Reliable Protection Systems Prevent: Power System Instability, Widespread Blackouts, Serious Equipment Damage, Injury and Loss of Life

❖ Protection Systems along with Telecommunications isolate electrically faulted Power System elements via rapid opening of circuit breakers

# Challenges - T&D Capacity Availability

## □ Transmission

- ❖ 80% of the Transmission System will need replacement in the next 15-20 years
- ❖ New investment in strengthening the transmission network over the next 3 years
  - Reduce bottlenecks
  - Maintain reliable service
  - Enable renewable generation connection to the grid

## □ Distribution

- ❖ Aging infrastructure
- ❖ Long and weak feeders
- ❖ Lack of communications infrastructure
- ❖ Provision for Distribution System Infrastructure upgrades

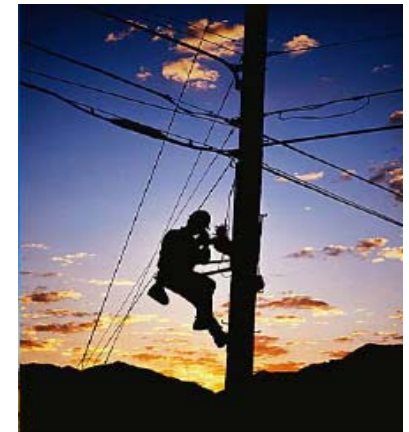

# Challenges – Increasing Number of DGs

## □ MicroFIT

	Number of Applications	Capacity (kW)
Biomass	4	40
Solar PV	1166	8382
Water	1	2
Wind	22	187
Total	1193	8611

## □ FIT

- ❖ 1,022 FIT applications
- ❖ 8,000 MW of potential electricity generation

### FIT Launch Applications

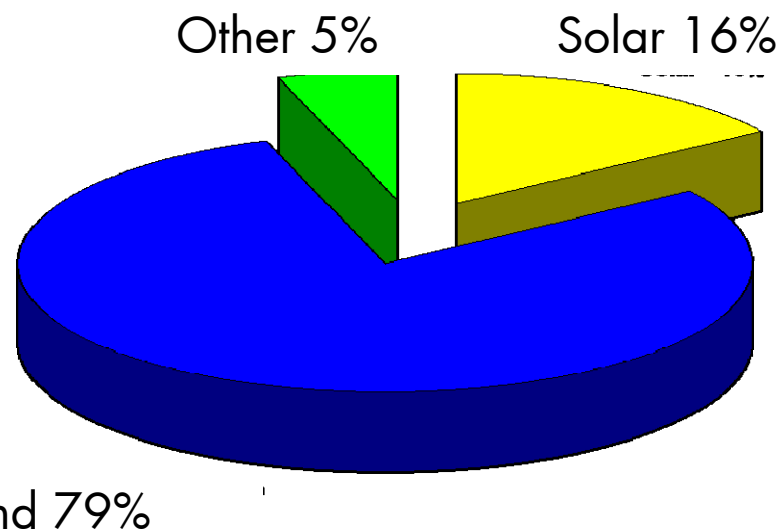

- ❖ 2,500 megawatts of available transmission connection capacity
- ❖ 1,500 MW of additional transmission capacity Bruce x Milton
- ❖ 6 Core Transmission Upgrades including Sudbury-Barrie-GTA
- ❖ 20 Distribution Enablement Projects

Source: Ontario Power Authority

# Opportunities

- ❑ Timely expansion or reinforcement of Transmission and Distribution systems
  - ❖ Facilitate Integration of new and emerging Distributed Generations
  - ❖ Promote the use of generation from renewable energy
  
- ❑ Harmonized set of Industry Standards
  - ❖ Address the technical challenges including power quality, network stability, fault levels, operability and sustainability of the Power Grid
  
- ❑ Enable the Distribution System to be more Intelligent
  - ❖ Develop Telecom Infrastructure as the foundation to accommodate DG operations and meet future requirements

# Conclusion

- By 2014, renewable energy will account for 40% of Ontario generation capacity. Renewable Energy will play an increasing role in the electric power system
- Transmission and Distribution play major roles in facilitating and enabling Distributed Generation connections
- Distributed Generation connections allow all stakeholders to work together proactively in addressing the new set of challenges and embrace the opportunities



# Hydro One at a Glance: Largest Electric Power Transmission and Distribution Company in Ontario

97% of transmission capacity  
30,000 km of transmission lines  
26 interconnection facilities for import/export  
23,000 km of distribution  
Over 1.3 million customers

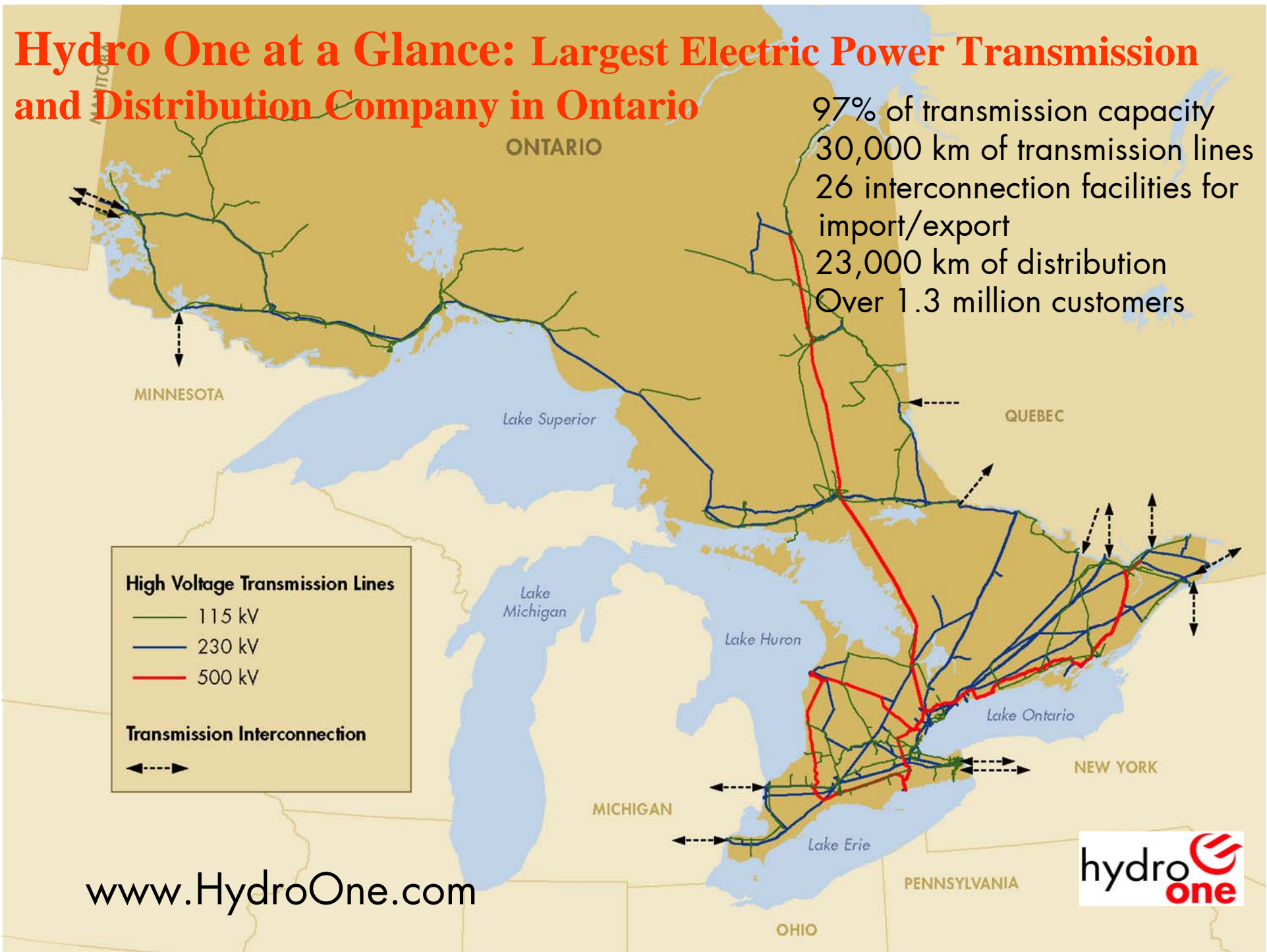

[www.HydroOne.com](http://www.HydroOne.com)



# Questions

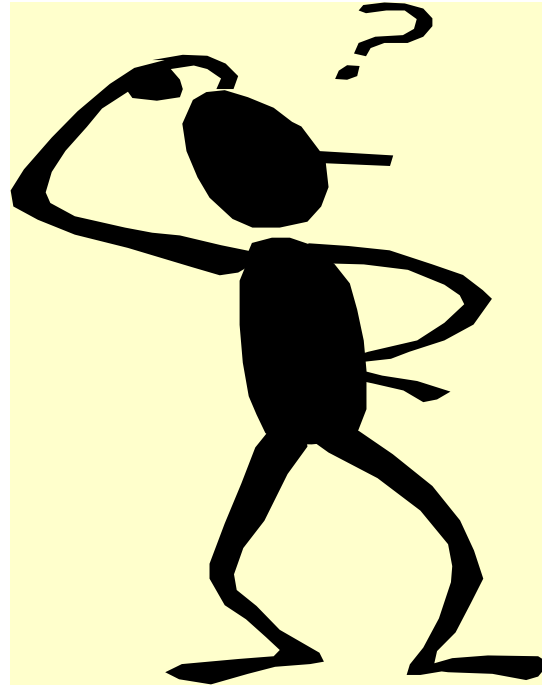

[Alourdes.Sully@HydroOne.com](mailto:Alourdes.Sully@HydroOne.com)